

Product Information Bulletin 359

EnerSpan EFS Insulation - Recommendations for Handling, Storage & Installation

Product Information Bulletin

BULLETIN NO.	359
ISSUED:	October 17, 2017
REPLACES:	NEW

EnerSpan® EFS Insulation Recommendations for Handling, Storage and Installation

EnerSpan® EFS insulation is rigid, closed cell, silver-gray insulation that meets or exceeds requirements for expanded polystyrene (EPS) insulation manufactured to CAN/ULC-S701¹, Annex A (see Plasti-Fab Product Information Bulletin 348) and ASTM E2430² (see Plasti-Fab Product Information Bulletin 349) for use in exterior insulation and finish systems (EIFS). **EnerSpan EFS** insulation is manufactured using **Neopor® F5300 GPS Plus**, a graphite-enhanced expandable polystyrene (GPS) raw material provided by **BASF**.

The graphite within the silver-gray cellular structure of **EnerSpan EFS** insulation reduces radiation heat transfer and results in an enhanced thermal resistance compared to standard white EPS insulation. The attached BASF bulletin (2 pages) provides recommendations for handling, storage and installation of **EnerSpan EFS** insulation made from **Neopor** used as a component in exterior insulation and finish system (EIFS) applications.



¹ **EnerSpan EFS** material properties as per CAN/ULC-S701, **Standard for Thermal Insulation, Polystyrene, Boards and Pipe Covering**, are third party certified under a quality listing program administered by Intertek. Intertek Code Compliance Research Report CCRR-1033 confirms compliance with the National Building Code of Canada 2010 and 2015.

² **EnerSpan EFS** insulation material properties are third party certified to requirements of ASTM E2430, **Standard Specification for Expanded Polystyrene (“EPS”) Thermal Insulation Boards for Use in Exterior Insulation and Finish Systems (“EIFS”)**, under a quality listing program administered by Intertek. Intertek Code Compliance Research Report CCRR-1033 confirms compliance with the 2009, 2012 and 2015 International Codes.

Neopor[®] GPS EIFS Overview

Overview:

The Neopor GPS Plus continuous exterior insulation foam product, which is graphite enhanced and offers superior thermal performance compared to other insulation materials. Neopor is widely used in the United States, Canada and Europe in a variety of applications including insulated stucco, siding, concrete forms, roofing, slabs on grade, residential sheathing, and EIFS.

Code Compliance:

Neopor is manufactured under a stringent industry leading quality program in UL Evaluation Report UL ER5817-02 and ICC-ES Report ESR-3463. Additionally, Neopor is approved for use in certain NFPA 285 approved wall assemblies.

Product Protection:

Like any building product material, Neopor insulation boards must be protected from the environment including reflection produced by the sun. Opaque covering is highly recommended such as white or blue tarps. Do not use clear stretch wraps. Please see storage and handling bulletin for additional information.

Fastening:

For future EIFS projects, the specification will indicate that Neopor GPS Plus is to be secured with supplementary mechanical fasteners immediately following board placement, while adhesive is still wet. Neopor may experience a slight curl under certain environmental conditions shortly after it is applied but prior to setting of the cementitious base coat adhesive; the fasteners temporarily secure the board while the cementitious base coat adhesive develops its final properties.

Testing and experience has demonstrated that once the cementitious base coat adhesive used to attach the Neopor GPS Plus has cured, a tenacious bond is formed with the substrate that provides long-term performance of the finished system.

Wind-lock Wind-Devil 2 plates (www.wind-lock.com) or equal, with appropriate type and length with corrosion resistant fasteners can be installed into framing or masonry. Fasteners can remain permanently in place. Recommended fastener frequency is shown below.

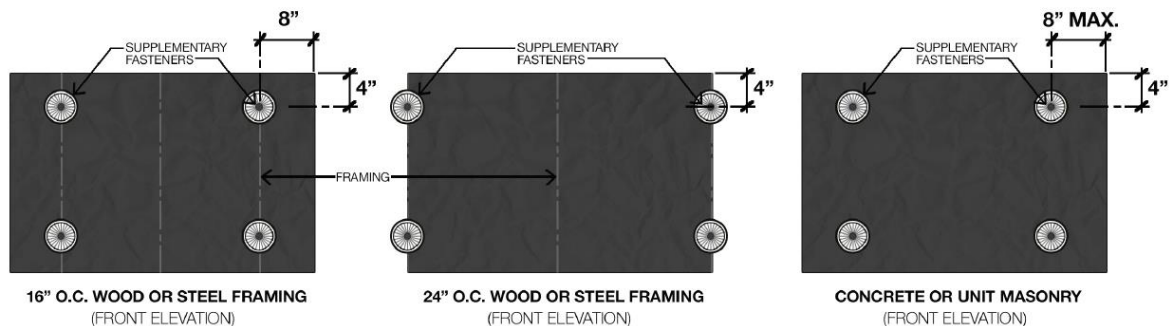



Installation:

As per system supplier installation instructions.

Environment:

Products made of Neopor have zero ozone-depletion potential and are GREENGUARD Gold certified for indoor air quality.

Availability:

Supplied across North America from BASF Neopor authorized manufacturers listed under UL ER 5817 and ICC ESR 3463 or visit our website:

www.Neopor-Insulation.com

Physical Properties

Thermal Resistance	°F·ft ² ·h/BTU (°C·m ² /W) at 75°F	R-5	R-7.5	R-10
		1-1/16"	1-5/8"	2-1/8"
Type I	ASTM C578 Classification			
Compressive Resistance	at yield of 10% deformation in psi (actual)	10	10	10
Vapor Permeance	Max permeance (perm per 1 inch)	4.0	4.0	4.0
Water Absorption	Max volume % absorbed	1.1	1.1	1.1
Density	lbs./ft ³ (min)	0.90	0.90	0.90
Type VIII	ASTM C578 Classification			
Compressive Resistance	at yield of 10% deformation in psi (actual)	14	14	14
Vapor Permeance	Max permeance (perm per 1 inch)	3.1	3.1	3.1
Water Absorption	Max volume % absorbed	1.1	1.1	1.1
Density	lbs./ft ³ (min)	1.15	1.15	1.15
Type II+	ASTM C578 Classification			
Compressive Resistance	at yield of 10% deformation in psi (actual)	20	20	20
Vapor Permeance	Max permeance (perm per 1 inch)	3.1	3.1	3.1
Water Absorption	Max volume % absorbed	1.1	1.1	1.1
Density	lbs./ft ³ (min)	1.45	1.45	1.45
Flame Spread	Index	5	5	5
Smoke Development	Index	25	25	25
Max Use Temperature	Maximum use temperature in °F	165	165	165

THE DESCRIPTIONS, DESIGNS, DATA AND INFORMATION CONTAINED HEREIN ARE PRESENTED IN GOOD FAITH, AND ARE BASED ON BASF'S CURRENT KNOWLEDGE AND EXPERIENCE. THEY ARE PROVIDED FOR GUIDANCE ONLY, AND DO NOT CONSTITUTE THE AGREED CONTRACTUAL QUALITY OF THE PRODUCT OR A PART OF BASF'S TERMS AND CONDITIONS OF SALE. BECAUSE MANY FACTORS MAY AFFECT PROCESSING OR APPLICATION USE OF THE PRODUCT, BASF RECOMMENDS THAT THE READER CARRY OUT ITS OWN INVESTIGATIONS AND TESTS TO DETERMINE THE SUITABILITY OF A PRODUCT FOR ITS PARTICULAR PURPOSE PRIOR TO USE. IT IS THE RESPONSIBILITY OF THE RECIPIENT OF PRODUCT TO ENSURE THAT ANY PROPRIETARY RIGHTS AND EXISTING LAWS AND LEGISLATION ARE OBSERVED. NO WARRANTIES OF ANY KIND, EITHER EXPRESS OR IMPLIED, INCLUDING, BUT NOT LIMITED TO, WARRANTIES OF MERCHANTABILITY OR FITNESS FOR A PARTICULAR PURPOSE, ARE MADE REGARDING PRODUCTS DESCRIBED OR DESIGNS, DATA OR INFORMATION SET FORTH HEREIN, OR THAT THE PRODUCTS, DESCRIPTIONS, DESIGNS, DATA OR INFORMATION MAY BE USED WITHOUT INFRINGING THE INTELLECTUAL PROPERTY RIGHTS OF OTHERS. ANY DESCRIPTIONS, DESIGNS, DATA AND INFORMATION GIVEN IN THIS PUBLICATION MAY CHANGE WITHOUT PRIOR INFORMATION. THE DESCRIPTIONS, DESIGNS, DATA AND INFORMATION FURNISHED BY BASF HEREUNDER ARE GIVEN GRATIS AND BASF ASSUMES NO OBLIGATION OR LIABILITY FOR THE DESCRIPTIONS, DESIGNS, DATA OR INFORMATION GIVEN OR RESULTS OBTAINED, ALL SUCH BEING GIVEN AND ACCEPTED AT THE READER'S RISK.

